

REV.	ECN NO	DESCRIPTION	REVISED	DATE
A		新订图面	LXM	16'.03.09

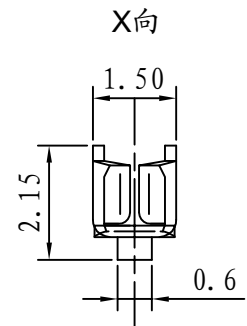
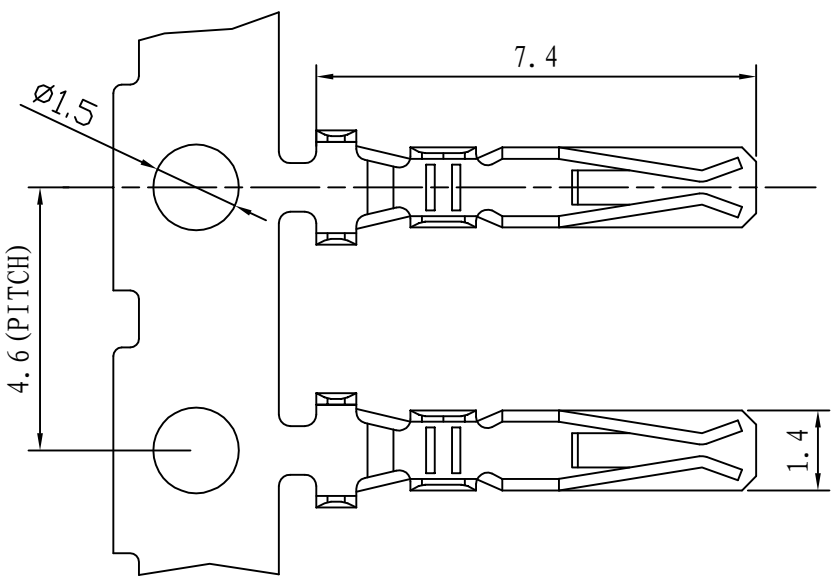
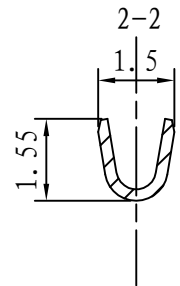
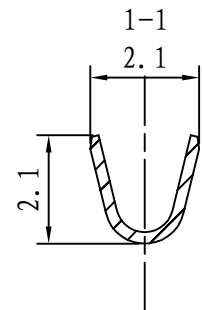
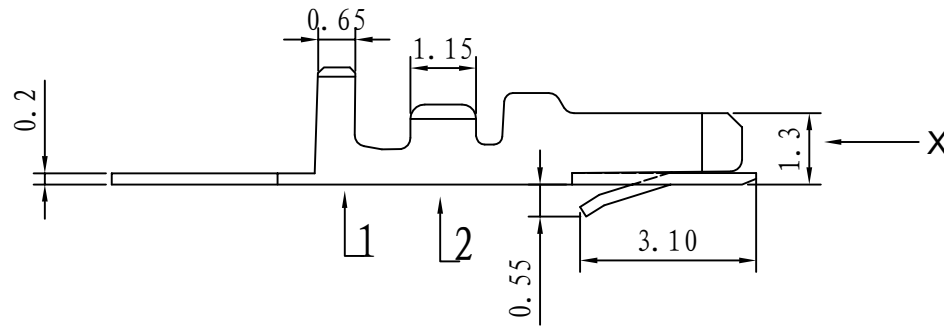

Specifications /技术规格:

Current Rating: 3A
 额定电流: 3A
 Insulation Resistance: 1000MΩ Min.
 绝缘电阻: 最小1000MΩ
 Dielectric Withstanding: 1000V AC
 耐电压: 1000V AC
 Contact Resistance: 20mΩ Max.
 接触电阻: 最大20mΩ
 Operating Temperature: -25°C to +85°C
 工作温度: -25°C 到 85°C

Materials /材料:

Contact Material: Phosphor Bronze(Sn plating)
 接触端子材料: 磷铜(镀锡)

 浙江快利电子有限公司
 Zhejiang Kuaili Electronic Co., Ltd

GENERAL TOLERANCE	
X. ± X.	.*** ± 0.05
.X ± X.	.** ± 0.10
.XX ± XX.	.* ± 0.20
.XXX ± 0.5.	*. ± 0.30

DESIGN:	李晓明	DATE:	16'.03.09
CHECKED:	李晓明	DATE:	16'.03.09
AUDITED:	曹德友	DATE:	16'.03.09
APPROVED:	朱建华	DATE:	16'.03.09

DWG. NO.	KL-XHD2.0-TE
PART NO.	

TITLE.	XHD2.0-TE
--------	-----------

REV.	A	UNIT.	MM	SCALE.	---	
------	---	-------	----	--------	-----	--