

REV.	ECN NO	DESCRIPTION	REVISED	DATE
A		新订图面	KEVIN	2015.09.18

ROHS

Specifications / 技术规格:

Current Rating: 3A
额定电流: 3A

Insulation Resistance: 1000MΩ Min.
绝缘电阻: 最小1000MΩ

Dielectric Withstanding: 1000V AC
耐电压: 1000V AC

Operating Temperature: -25°C to +85°C
工作温度: -25°C 到 85°C

Materials / 材料:
Insulation Material: PA or PBT UL94V-2 Natural
绝缘体塑胶材料: PA或PBT UL94V-2 本色

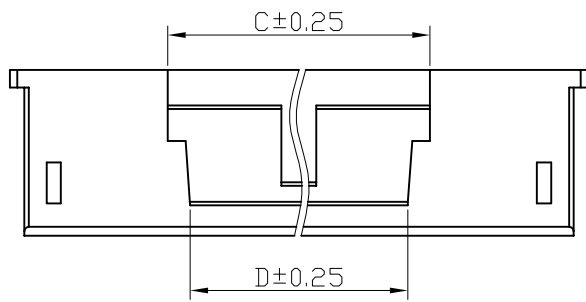
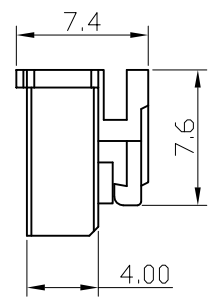
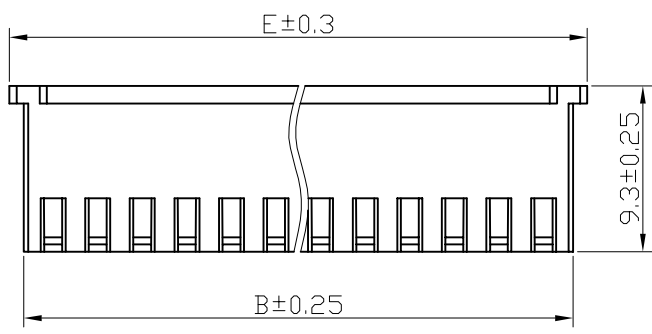
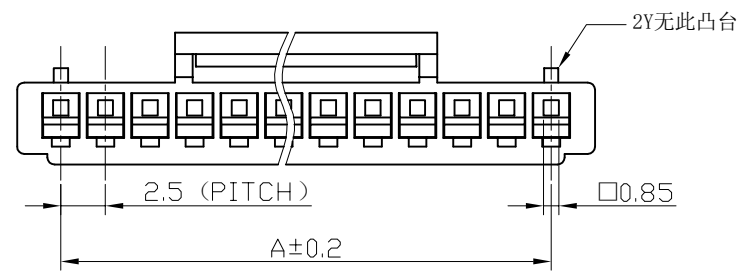
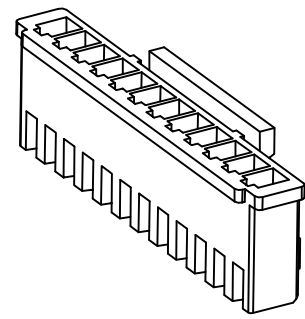

型号	尺寸 (mm)				
	A	B	C	D	E
XHB-2Y	2.50	5.90	5.00	2.70	7.50
XHB-3Y	5.00	8.40	4.00	1.85	10.00
XHB-4Y	7.50	10.90	5.00	2.85	12.50
XHB-5Y	10.00	13.40	7.20	5.10	15.00
XHB-6Y	12.50	15.90	9.70	7.60	17.50
XHB-7Y	15.00	18.40	12.20	10.10	20.00
XHB-8Y	17.50	20.90			22.50
XHB-9Y	20.00	23.40	14.70	12.60	25.00
XHB-10Y	22.50	25.90			27.50
XHB-11Y	25.00	28.40			30.00
XHB-12Y	27.50	30.90			32.50
XHB-13Y	30.00	33.40	14.70	12.60	35.00
XHB-14Y	32.50	35.90			37.50
XHB-15Y	35.00	38.40			40.00
XHB-16Y	37.50	40.90			42.50

浙江快利电子有限公司
Zhejiang Kuaili Electronic Co., Ltd

GENERAL TOLERANCE		DESIGN:	DATE:
X. ± 3'	X. --	KEVIN	15'.9.18
.X ± 2'	.X ± 0.30	CHECKED: 朱前程	DATE: 15'.9.18
.XX ± 1'	.XX ± 0.20	AUDITED: 张宁	DATE: 15'.9.18
.XXX ± 0.5'	.XXX --	APPROVED: 朱建华	DATE: 15'.9.18

DWG. NO.	KL-XHB-NY
PART NO.	

TITLE:	XHB-NY
--------	--------

REV.	A	UNIT.	MM	SCALE.	1:1	
------	---	-------	----	--------	-----	--