

REV.	ECN NO	DESCRIPTION	REVISED	DATE
A		新订图面	HELLER	2016.8.13

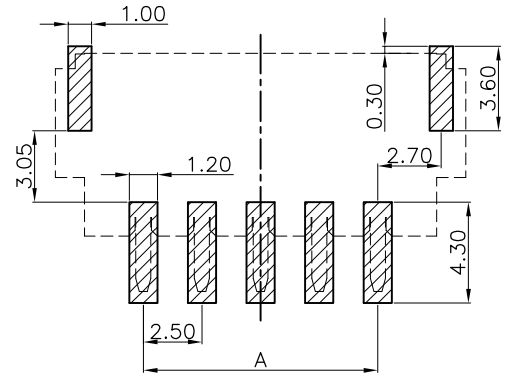

P.C.B. LAYOUT

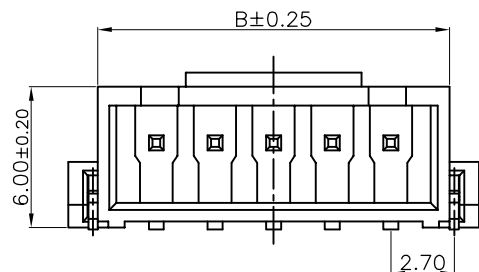
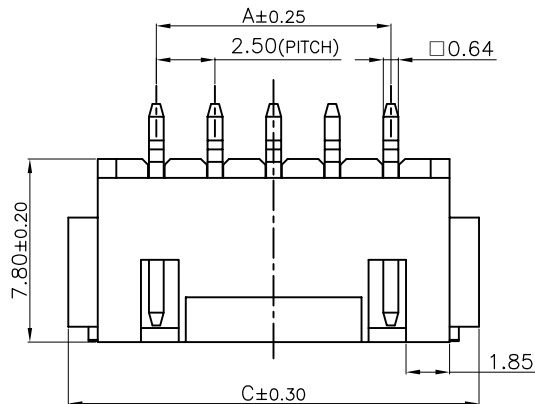
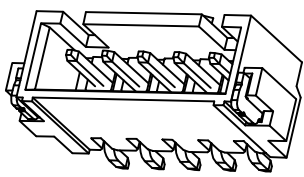
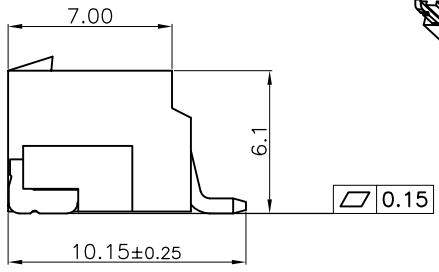

孔数	型号	尺寸 (mm)		
		A	B	C
2	XHB-2AWT	2.5	7.5	10.0
3	XHB-3AWT	5.0	10.0	12.5
4	XHB-4AWT	7.5	12.5	15.0
5	XHB-5AWT	10.0	15.0	17.5
...
16	XHB-16AWT	37.5	42.5	45.0

ROHS

Specifications / 技术规格:

Current rating: 3A
 额定电流: 3A
 Voltage rating: 250V AC,DC
 额定电压: 250V AC,DC
 Insulation Resistance: 1000MΩ Min.
 绝缘电阻: 最小1000MΩ
 Dielectric Withstanding: 1000V AC 1Min
 耐电压: 1000V AC 1分钟
 Contact Resistance: 20mΩ Max.
 接触电阻: 最大20mΩ
 Operating Temperature: -25°C to +85°C
 工作温度: -25°C 到85°C

Materials / 材料:

Contact Material: Brass(Tin plating)
 接触铜针材料: 黄铜(镀锡)
 Soldering Terminal: Bronze(Tin plating)
 焊片材料: 磷铜(镀锡)
 Insulation Material: LCP or PA UL94V-0
 绝缘体材料: LCP or PA UL94V-0

浙江快利电子有限公司
 Zhejiang Kuaili Electronic Co., Ltd

GENERAL TOLERANCE	
X.* ± 3'	.XXX ±0.10
.X* ± 2'	.XX ±0.15
.XX* ± 1'	.X ±0.25
.XXX* ± 0.5'	X. ±0.35

DESIGN:	HELLER	DATE:	2016.8.13
CHECKED:	瞿益远	DATE:	2016.8.13
AUDITED:	张宁	DATE:	2016.8.13
APPROVED:	朱建华	DATE:	2016.8.13

DWG. NO.	KL-XHB-NAWT
PART NO.	

TITLE:
XHB-NAWT连接器

REV.	A	UNIT.	MM	SCALE.	1:1