

REV.	ECN NO	DESCRIPTION	REVISED	DATE
A		新订图面	KEVIN	2016.4.18

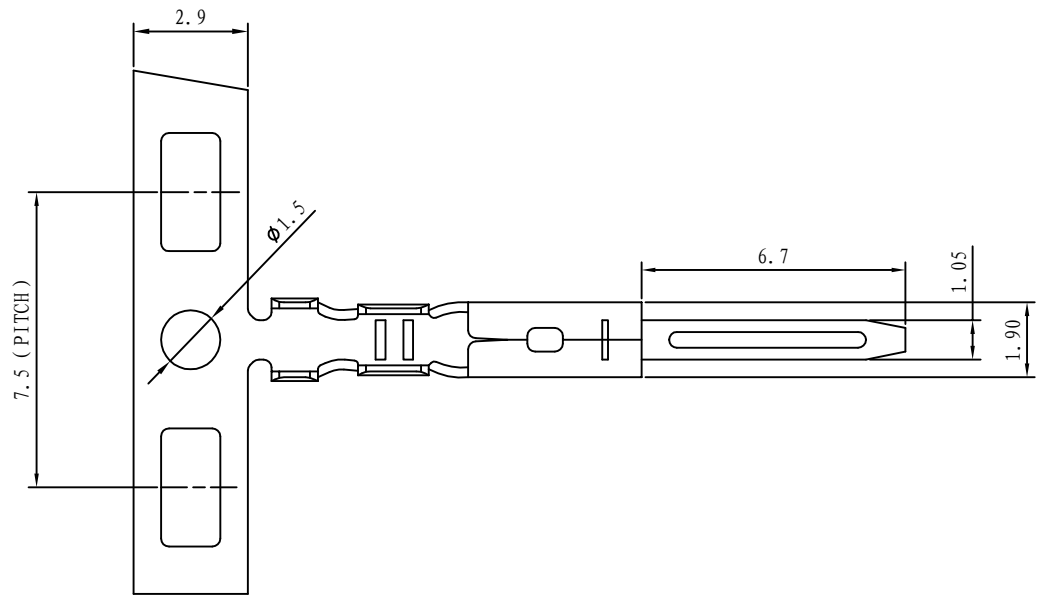
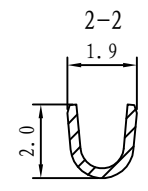
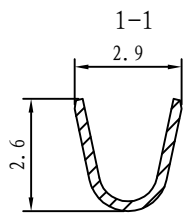
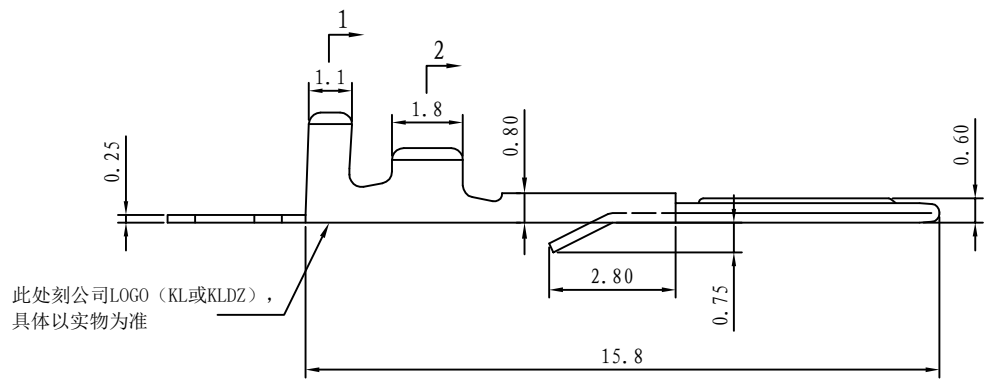

Specifications / 技术规格:

Current Rating: 3A
 额定电流: 3A

Insulation Resistance: 1000MΩ Min.
 绝缘电阻: 最小1000MΩ

Dielectric Withstanding: 1000V AC
 耐电压: 1000V AC

Contact Resistance: 20mΩ Max.
 接触电阻: 最大20mΩ

Operating Temperature: -25°C to +85°C
 工作温度: -25°C 到 85°C

Materials / 材料:

Contact Material: Phosphor Bronze (Tin plating)
 接触端子材料: 磷铜 (镀锡)

 浙江快利电子有限公司
 ZheJiang Kuaili Electronic Co., LTD.

GENERAL TOLERANCE	
X.: ± 3°	X.: ± 0.35
.X: ± 2°	X.X: ± 0.25
.XX: ± 1°	X.XX: ± 0.15
.XXX: ± 0.5°	X.XXX: ± 0.10

DESIGN:	KEVIN	DATE:	2016-04-18
CHECKED:	李晓明	DATE:	2016-04-18
APPROVED:	朱建华	DATE:	2016-04-18

DWG. NO.	
PART NO.	KL-SMA-TE

TITLE.	SMA-TE (32)
--------	-------------

REV.	UNIT.	SCALE.	PAGE.	PROJ.
A	mm	-	1/1	