

REV.	ECN NO	DESCRIPTION	REVISED	DATE
A		新订图面	KEVIN	

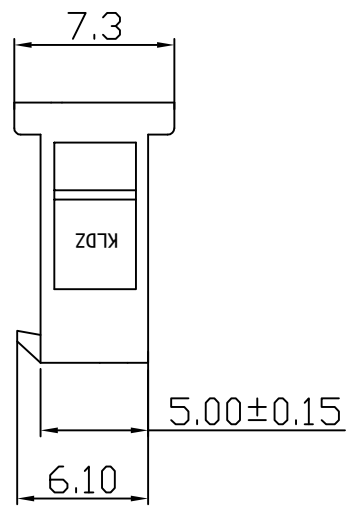
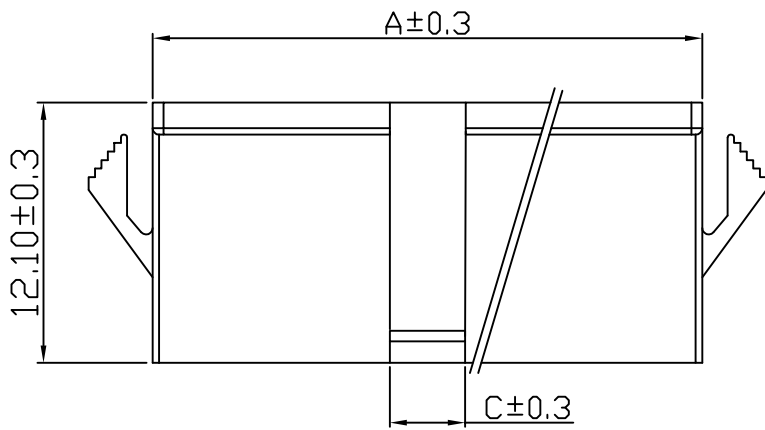
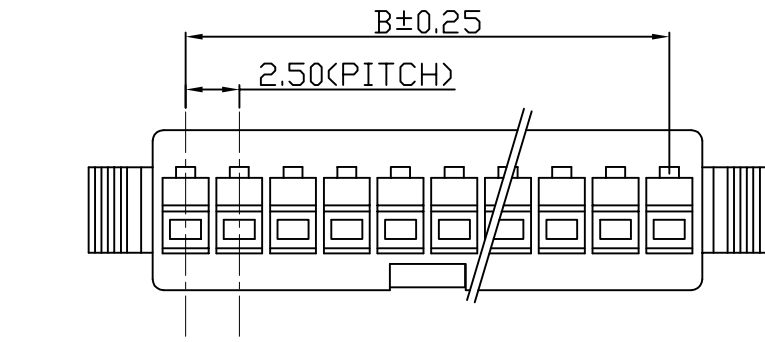

ROHS

Specifications / 技术规格:

Current rating: 3A
 额定电流: 3A
 Voltage rating: 250V AC,DC
 额定电压: 250V AC,DC
 Insulation Resistance: 500MΩ Min.
 绝缘电阻: 最小500MΩ
 Dielectric Withstanding: 1500V AC 1Min
 耐电压: 1500V AC 1分钟
 Contact Resistance: 20mΩ Max.
 接触电阻: 最大20mΩ
 Operating Temperature: -25°C to +85°C
 工作温度: -25°C 到 85°C

Materials / 材料:

Insulation Material: NYLON UL94V-2 BLACK
 绝缘体塑胶材料: 尼龙 UL94V-2 黑色

孔数	A	B	C
2	5.5	2.50	2.80
3	8.0	5.00	3.50
4	10.5	7.50	3.50
5	13.0	10.00	3.50
6	15.5	12.50	3.50
7	18.0	15.00	3.50
8	20.5	17.50	3.50
9	23.0	20.00	3.50
10	25.5	22.50	3.50
11	28.0	25.00	3.50
12	30.5	27.50	3.50
13	33.0	30.00	3.50
14	35.5	32.50	3.50
15	38.0	35.00	3.50
16	40.5	37.50	3.50

 **浙江快利电子有限公司**
 Zhejiang Kuaili Electronic Co., Ltd

GENERAL TOLERANCE	
X.° ± 3°	.XXX: ±0.10
.X° ± 2°	.XX: ±0.15
.XX° ± 1°	.X: ±0.25
.XXX° ± 0.5°	X.: ±0.35

DESIGN:	KEVIN	DATE:	2015-3-10
CHECKED:		DATE:	
AUDITED:		DATE:	
APPROVED:		DATE:	

DWG. NO.	
PART NO.	KL-SM-NY

TITLE.	SM-NY
--------	-------

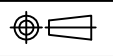
REV.	A	UNIT.	MM	SCALE.	1:1	
------	---	-------	----	--------	-----	---