

RoHS	REV.	ECN NO	DESCRIPTION	REVISED	DATE
	A		新订图面	KEVIN	15.03.10

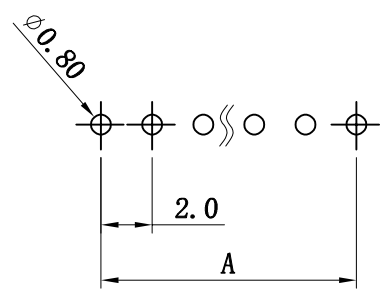
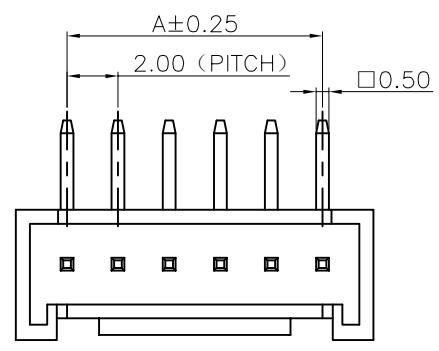

Recommended P.C.Board Hole Layout

Specifications / 技术规格:

Current rating: 2A
 额定电流: 2A
 Voltage rating: 100V AC,DC
 额定电压: 100V AC, DC
 Insulation Resistance: 1000MΩ Min.
 绝缘电阻: 最小1000MΩ
 Dielectric Withstanding: 800V AC 1Min
 耐电压: 800V AC 1分钟
 Contact Resistance: 20mΩ Max.
 接触电阻: 最大20mΩ
 Operating Temperature: -25°C to +85°C
 工作温度: -25°C 到85°C

Materials / 材料:
 Contact Material: Brass(Sn plating)
 接触端子材料: 黄铜(镀锡)
 Insulation Material: PA or PBT UL94V-0 Natural
 绝缘体塑胶材料: PA 或 PBT UL94V-0 本色

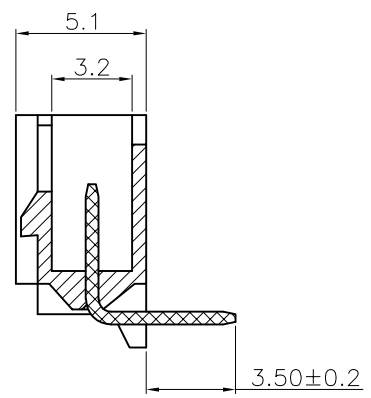
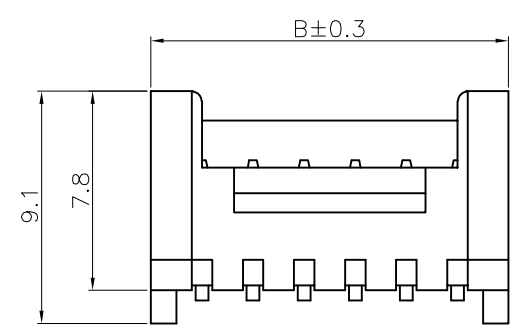

CKT.	DIM(mm)	
	A	B
2	2.00	6.00
3	4.00	8.00
4	6.00	10.00
5	8.00	12.00
6	10.00	14.00
7	12.00	16.00
8	14.00	18.00
9	16.00	20.00
10	18.00	22.00
11	20.00	24.00
12	22.00	26.00
13	24.00	28.00
14	26.00	30.00
15	28.00	32.00
16	30.00	34.00

浙江快利电子有限公司
 Zhejiang Kuaili Electronic Co., Ltd

REV.	A	UNIT.	MM	SCALE.	1:1	
------	---	-------	----	--------	-----	--

GENERAL TOLERANCE		DESIGN: KEVIN	DATE: 2015-3-10	DWG. NO.	TITLE.
X.* ± 3'	.XXX : --	CHECKED:	DATE:		
.X* ± 2'	.XX : ±0.20	AUDITED:	DATE:	PART NO.	PHS-NAWD
.XX* ± 1'	.X : ±0.30	APPROVED:	DATE:		
.XXX* ± 0.5'	X. : --				