

RoHS

REV.	ECN NO	DESCRIPTION	REVISED	DATE
A		新订图面	KEVIN	

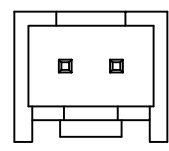

PHS-2A

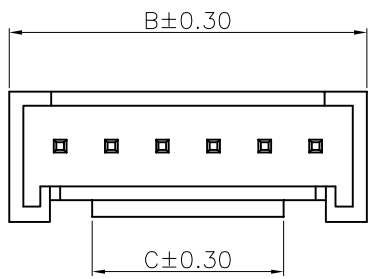
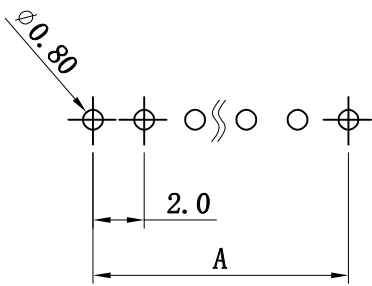

Recommended P.C.Board Hole Layout

Specifications / 技术规格:

Current rating: 2A
 额定电流: 2A
 Voltage rating: 100V AC,DC
 额定电压: 100V AC, DC
 Insulation Resistance: 1000MΩ Min.
 绝缘电阻: 最小1000MΩ
 Dielectric Withstanding: 800V AC 1Min
 耐电压: 800V AC 1分钟
 Contact Resistance: 20mΩ Max.
 接触电阻: 最大20mΩ
 Operating Temperature: -25°C to +85°C
 工作温度: -25°C 到 85°C

Materials / 材料:
 Contact Material: Brass(Sn plating)
 接触端子材料: 黄铜(镀锡)
 Insulation Material: PA or PBT UL94V-0 Natural
 绝缘体塑胶材料: PA 或 PBT UL94V-0 本色

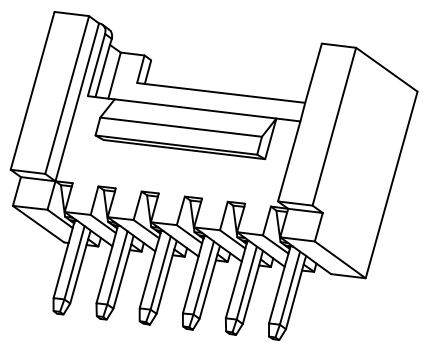
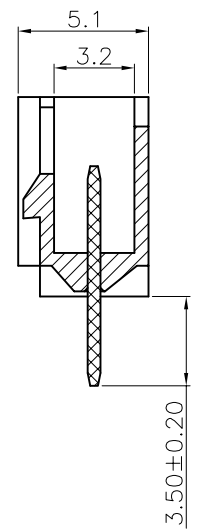
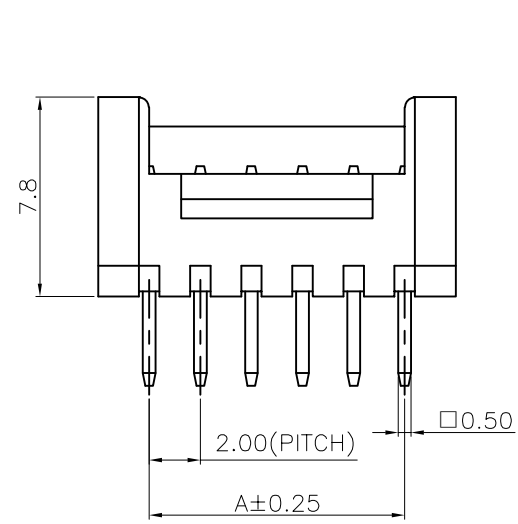

CKT.	DIM(mm)		
	A	B	C
2	2.00	6.00	2.4
3	4.00	8.00	2.9
4	6.00	10.00	3.5
5	8.00	12.00	5.5
6	10.00	14.00	7.5
7	12.00	16.00	9.5
8	14.00	18.00	11.5
9	16.00	20.00	13.5
10	18.00	22.00	15.5
11	20.00	24.00	17.5
12	22.00	26.00	19.5
13	24.00	28.00	21.5
14	26.00	30.00	23.5
15	28.00	32.00	25.5
16	30.00	34.00	27.5

浙江快利电子有限公司
 Zhejiang Kuaili Electronic Co., Ltd

GENERAL TOLERANCE	
X.* ± 3'	.XXX --
.X* ± 2'	.XX ±0.25
.XX* ± 1'	.X ±0.35
.XXX* ± 0.5'	X. --

DESIGN:	KEVIN	DATE:	2015.3.10
CHECKED:		DATE:	
AUDITED:		DATE:	
APPROVED:		DATE:	

DWG. NO.	
PART NO.	KL-PHS-NA-02-BE

TITLE.	PHS-NA
--------	--------

REV.	A	UNIT.	MM	SCALE.	1:1	
------	---	-------	----	--------	-----	--