

REV.	ECN NO	DESCRIPTION	REVISED	DATE
A		新订图面	QYY	2016.5.10

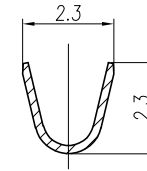

SECT. A-A

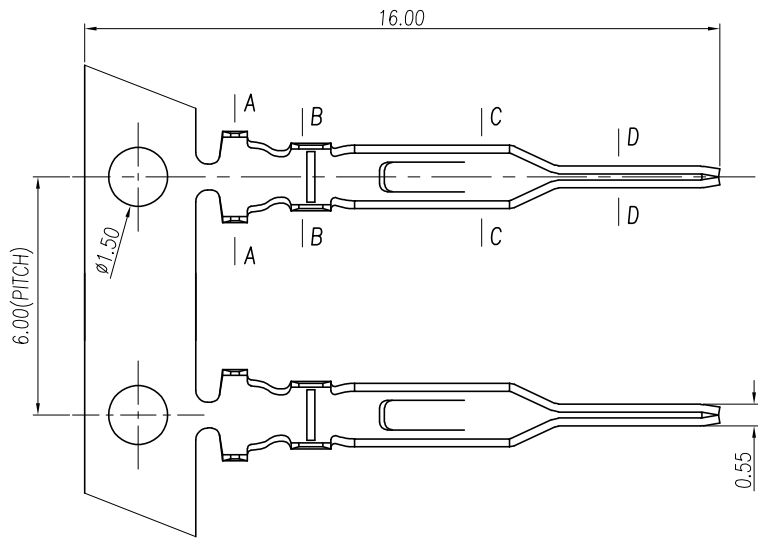
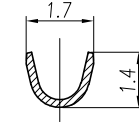

SECT. B-B

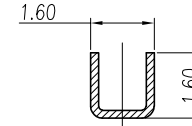

SECT. C-C

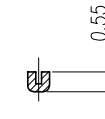

SECT. D-D

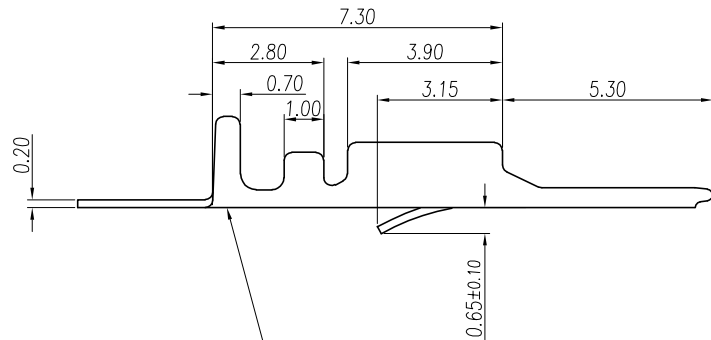

此处刻公司LOGO (KLDZ或KL),具体以实物为准。

Specifications / 技术规格:

- Current Rating: 2A  
额定电流: 2A
- Insulation Resistance: 1000MΩ Min.  
绝缘电阻: 最小1000MΩ
- Dielectric Withstanding: 800V AC  
耐电压: 800V AC
- Contact Resistance: 20mΩ Max.  
接触电阻: 最大20mΩ
- Operating Temperature: -25°C to +85°C  
工作温度: -25°C 到 85°C

Materials / 材料:

- Contact Material: Phosphor Bronze (Tin plating)  
接触端子材料: 磷铜 (镀锡)
- Recommended wire gauge: AWG24#-28#  
推荐线规: AWG24#-28#

 浙江快利电子有限公司  
ZheJiang KuaiLi Electronic Co., Ltd.

GENERAL TOLERANCE

X° ± 3'	X.	±0.35
.X° ± 2'	.X	±0.25
.XX° ± 1'	.XX	±0.15
.XXX° ± 0.5'	.XXX	±0.10

DESIGN: QYY

DATE: 2016.5.10

DWG. NO.

TITLE.

CHECKED:

DATE:

PART NO.

PHS-AT

APPROVED:

DATE:

KL-PHS-AT-2824

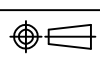
REV.	UNIT.	SCALE.	
A	MM	-	