

REV.	ECN NO	DESCRIPTION	REVISED	DATE
A		新订图面	LXM	16'.03.09

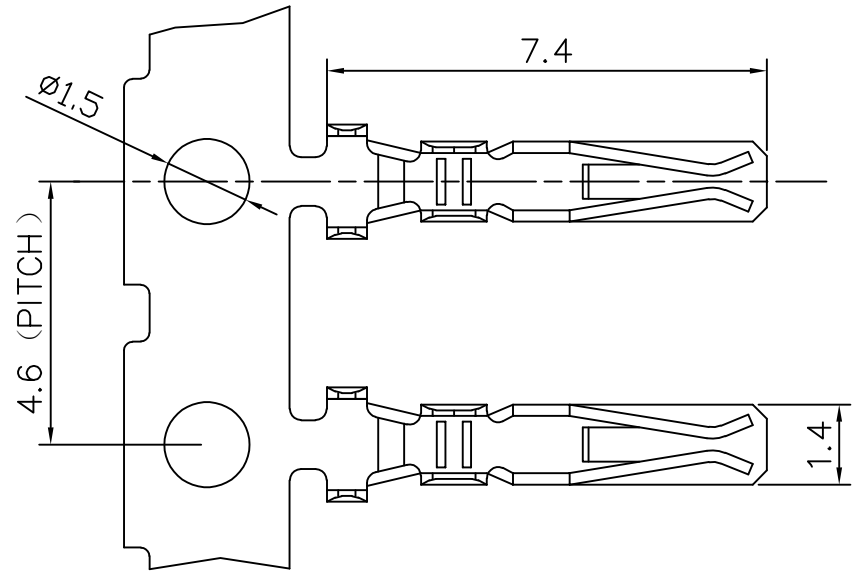
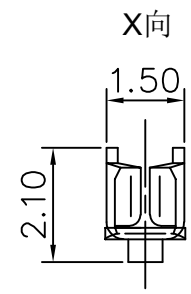
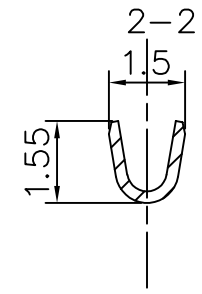
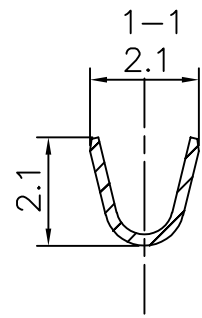
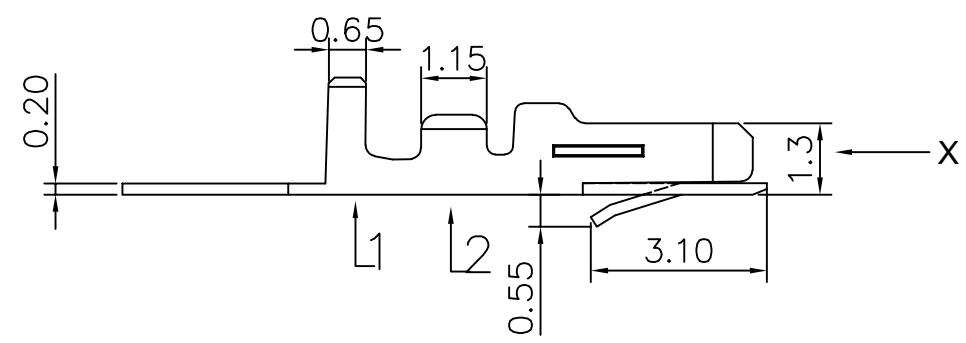

Specifications / 技术规格:

Current Rating: 3A
 额定电流: 3A
 Insulation Resistance: 1000M Ω Min.
 绝缘电阻: 最小1000M Ω
 Dielectric Withstanding: 800V AC
 耐电压: 800V AC
 Contact Resistance: 20m Ω Max.
 接触电阻: 最大20m Ω
 Operating Temperature: -25°C to +85°C
 工作温度: -25°C 到 85°C

Materials / 材料:

Contact Material: Phosphor Bronze(Tin plating)
 接触端子材料: 磷铜(镀锡)
 Recommended wire gauge: AWG28#-24#
 推荐线规: AWG28#-24#

 **浙江快利电子有限公司**
 Zhejiang Kuaili Electronic Co., Ltd

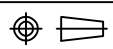
REV.	A	UNIT.	MM	SCALE.	---	
------	---	-------	----	--------	-----	-------------------------------------------------------------------------------------

GENERAL TOLERANCE	
X.* ± X.*	.*** ±0.10
.X* ± X.	.** ±0.15
.XX* ± XX.	. * ±0.25
.XXX* ± 0.5*	*. ±0.35

DESIGN:	李晓明	DATE:	16'.03.09
CHECKED:	李晓明	DATE:	16'.03.09
AUDITED:	瞿益远	DATE:	16'.03.09
APPROVED:	朱建华	DATE:	16'.03.09

DWG. NO.	
PART NO.	KL-PHB-TE-2824

TITLE.	PHB-TE
--------	--------