

REV.	ECN NO	DESCRIPTION	REVISED	DATE
A		新订图面	KEVIN	

RoHS

Specifications / 技术规格:

Current Rating: 3A AC,DC(AWG#24)
 额定电流: 3A AC, DC(AWG#24)

Insulation Resistance: 1000MΩ Min.
 绝缘电阻: 最小1000MΩ

Dielectric Withstanding: 800V AC
 耐电压: 800V AC

Operating Temperature: -25°C to +85°C
 工作温度: -25°C 到 85°C

Materials / 材料:

Insulation Material: PA or PBT UL94V-2
 绝缘体塑胶材料: PA 或 PBT UL94V-2

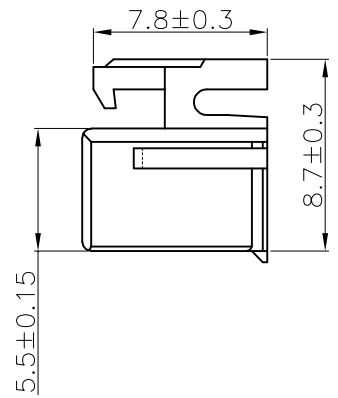
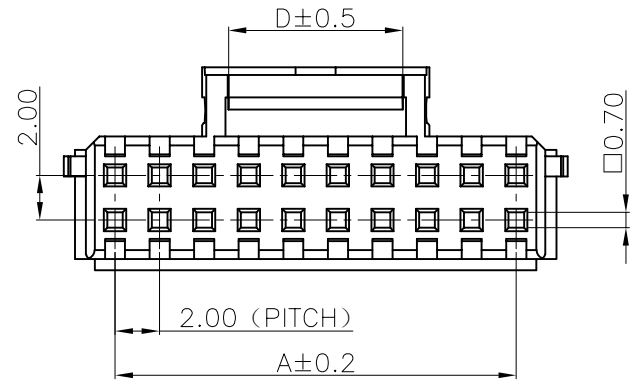
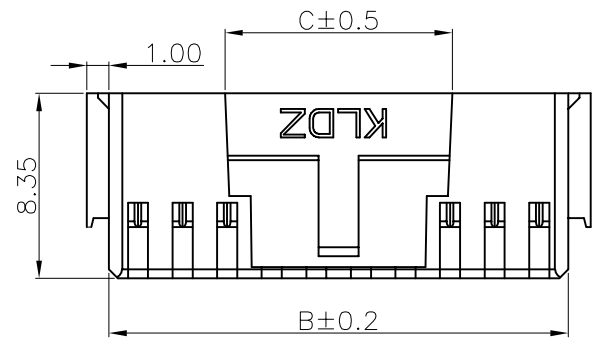
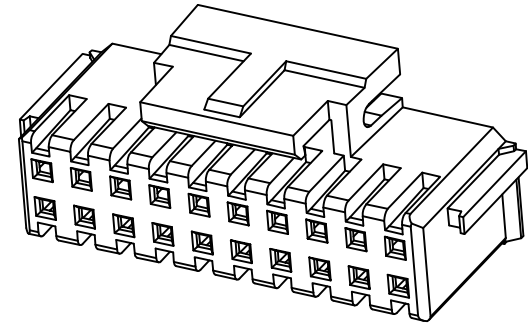

孔数	尺寸 (mm)			
	A	B	C	D
2X2	2.0	4.6	3.1	1.45
2X3	4.0	6.6	3.4	1.55
2X4	6.0	8.6	5.1	2.6
2X5	8.0	10.6	6.0	3.6
2X6	10.0	12.6	8.2	5.8
2X7	12.0	14.6		
2X8	14.0	16.6	8.2/13.7	5.8/11.05
2X9	16.0	18.6		
2X10	18.0	20.6	10.2	7.8
2X11	20.0	22.6		
2X12	22.0	24.6	10.2/16.2	7.8/13.8
2X13	24.0	26.7		
2X14	26.0	28.7	16.2	13.8
2X15	28.0	30.7		
2X16	30.0	32.7		
2X17	32.0	34.7		
2X18	34.0	36.7		
2X19	36.0	38.7		
2X20	38.0	40.7		

浙江快利电子有限公司
 Zhejiang Kuaili Electronic Co., Ltd

GENERAL TOLERANCE	
X.* ± 3'	X.* --
.X* ± 2'	.X ± 0.30
.XX* ± 1'	.XX ± 0.20
.XXX* ± 0.5'	.XXX --

DESIGN:	KEVIN	DATE:	15'.07.02
CHECKED:	朱前程	DATE:	15'.07.02
AUDITED:	张宁	DATE:	15'.07.02
APPROVED:	朱建华	DATE:	15'.07.02

DWG. NO.	PART NO. KL-PHB-2xNY-01-W
TITLE.	

TITLE:
PHB-2xNY

REV.	A	UNIT.	MM	SCALE.	1:1	
------	---	-------	----	--------	-----	--