

REV.	ECN NO	DESCRIPTION	REVISED	DATE
A		新订图面	KEVIN	2015.03.10

ROHS

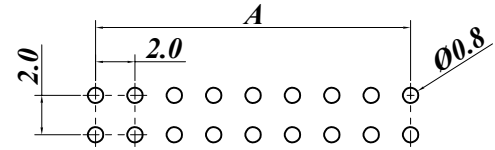

Recommended P.C.Board Hole Layout

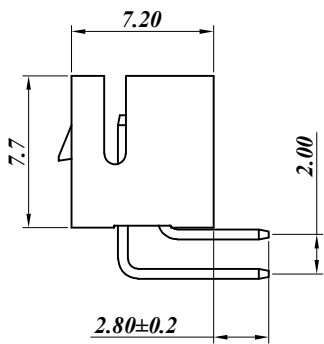
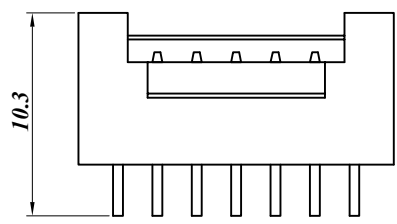
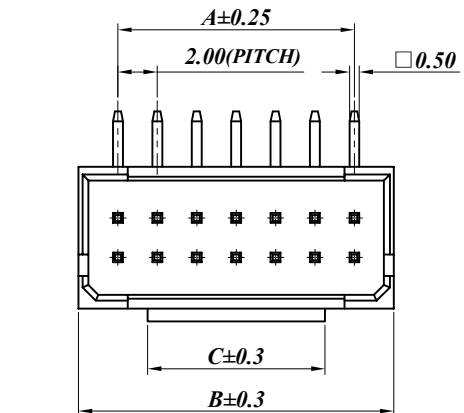

PIN数	DIM		
	A	B	C
2X2	2.0	6.0	3.0
2X3	4.0	8.0	3.0
2X4	6.0	10.0	3.0
2X5	8.0	12.0	5.0
2X6	10.0	14.0	7.0
2X7	12.0	16.0	9.0
2X8	14.0	18.0	11.0
2X9	16.0	20.0	13.0
2X10	18.0	22.0	15.0
2X11	20.0	24.0	17.0
2X12	22.0	26.0	19.0
2X13	24.0	28.0	21.0
2X14	26.0	30.0	23.0
2X15	28.0	32.0	25.0
2X16	30.0	34.0	27.0
2X17	32.0	36.0	29.0
2X18	34.0	38.0	31.0
2X19	36.0	40.0	33.0
2X20	38.0	42.0	35.0

Specifications / 技术规格:

Current rating: 3A AC,DC(AWG#24)

额定电流: 3A AC, DC(AWG#24)

Voltage rating: 250V AC,DC

额定电压: 250V AC, DC

Insulation Resistance: 1000MΩ Min.

绝缘电阻: 最小1000MΩ

Dielectric Withstanding: 800V AC 1Min

耐电压: 800V AC 1分钟

Contact Resistance: 20mΩ Max.

接触电阻: 最大20mΩ

Operating Temperature: -25°C to +85°C

工作温度: -25° C 到85° C

Materials / 材料:

Contact Material: Brass(Tin plating)

接触端子材料: 黄铜(镀锡)

Insulation Material: PA or PBT UL94V-0

绝缘体塑胶材料: PA 或 PBT UL94V-0

浙江快利电子有限公司
Zhejiang Kuaili Electronic Co., Ltd

GENERAL TOLERANCE

X.° ± 3°	X. --
.X° ± 2°	.X ±0.30
.XX° ± 1°	.XX ±0.20
.XXX ± 0.5°	.XXX --

DESIGN: KEVIN

CHECKED: 朱前程

AUDITED: 张宁

APPROVED: 朱建华

DATE: 15.3.10

DATE: 15.3.10

DATE: 15.3.10

DATE: 15.3.10

DWG. NO.

PART NO.

KL-PHB-2XNAW-02-BE

TITLE.

PHB-2XNAW 连接器

REV. A	UNIT. MM	SCALE. 1:1	
--------	----------	------------	--