

RoHS

| REV. | ECN NO | DESCRIPTION | REVISED | DATE |
|------|--------|-------------|---------|------|
| A | | 新订图面 | KEVIN | |

Specifications/技术规格:

Current rating: 2A
 额定电流: 2A
 Voltage rating: 100V AC,DC
 额定电压: 100V AC,DC
 Insulation Resistance: 1000MΩ Min.
 绝缘电阻: 最小1000MΩ
 Dielectric Withstanding: 800V AC 1Min
 耐电压: 800V AC 1分钟
 Contact Resistance: 20mΩ Max.
 接触电阻: 最大20mΩ
 Operating Temperature: -25°C to +85°C
 工作温度: -25°C 到85°C

Materials/材料:

Contact Material: Carobronze(Sn plating)
 接触端子材料: 磷铜(镀锡)
 Insulation Material: LCP or PA UL94V-0
 绝缘体材料: LCP 或 PA UL94V-0

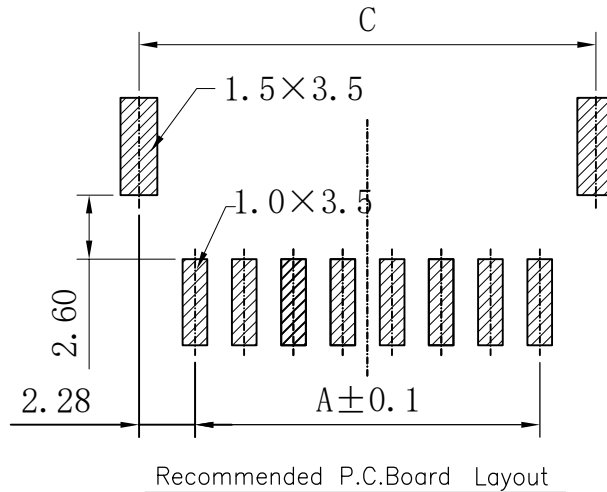
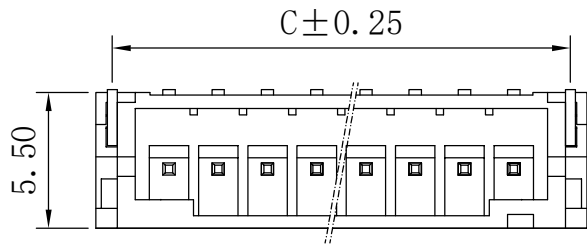

Recommended P.C.Board Layout

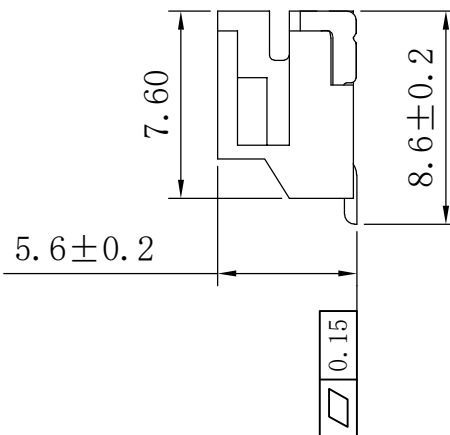
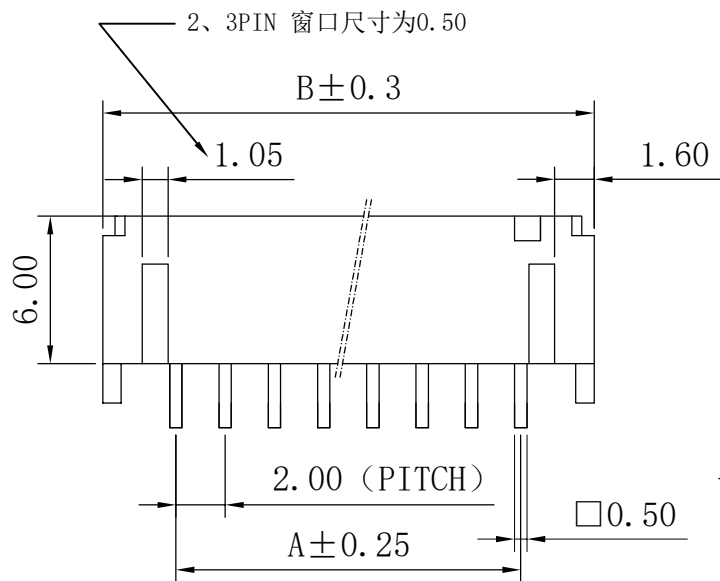

| CKT. | 尺寸 (mm) | | |
|------|---------|------|-------|
| | A | B | C |
| 2 | 2.0 | 8.0 | 6.60 |
| 3 | 4.0 | 10.0 | 8.60 |
| 4 | 6.0 | 12.0 | 10.60 |
| 5 | 8.0 | 14.0 | 12.60 |
| 6 | 10.0 | 16.0 | 14.60 |
| 7 | 12.0 | 18.0 | 16.60 |
| 8 | 14.0 | 20.0 | 18.60 |
| 9 | 16.0 | 22.0 | 20.60 |
| 10 | 18.0 | 24.0 | 22.60 |
| 11 | 20.0 | 26.0 | 24.60 |
| 12 | 22.0 | 28.0 | 26.60 |
| 13 | 24.0 | 30.0 | 28.60 |
| 14 | 26.0 | 32.0 | 30.60 |
| 15 | 28.0 | 34.0 | 32.60 |
| 16 | 30.0 | 36.0 | 34.60 |

浙江快利电子有限公司
 Zhejiang Kuaili Electronic Co., Ltd

| GENERAL TOLERANCE | |
|-------------------|-------------|
| X.* ± 3' | .XXX: ±0.10 |
| .X* ± 2' | .XX : ±0.15 |
| .XX* ± 1' | .X : ±0.25 |
| .XXX* ± 0.5' | X. : ±0.35 |

| | | | |
|-----------|-------|-------|----------|
| DESIGN: | KEVIN | DATE: | 15'.3.10 |
| CHECKED: | | DATE: | |
| AUDITED: | | DATE: | |
| APPROVED: | | DATE: | |

| | |
|----------|------------------|
| DWG. NO. | |
| PART NO. | KL-PH-NAWT-04-BE |

TITLE:
PH-NAWT连接器

| | | | | | | |
|------|---|-------|----|--------|-----|--|
| REV. | A | UNIT. | MM | SCALE. | 1:1 | |
|------|---|-------|----|--------|-----|--|