

1 2 3 4 5 6 7 8 9

REV.	ECN NO	DESCRIPTION	REVISED	DATE
A		新订图面	KEVIN	

CKT.	A	B
2	2.00	6.00
3	4.00	8.00
4	6.00	10.00
5	8.00	12.00
6	10.00	14.00
7	12.00	16.00
8	14.00	18.00
9	16.00	20.00
10	18.00	22.00
11	20.00	24.00
12	22.00	26.00
13	24.00	28.00
14	26.00	30.00
15	28.00	32.00
16	30.00	34.00

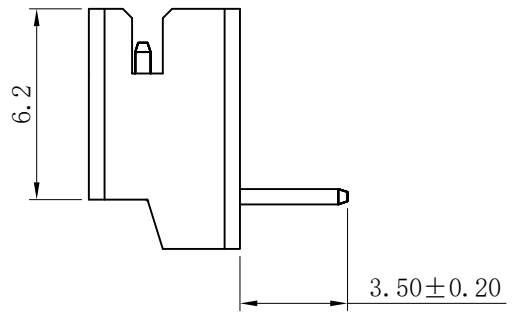
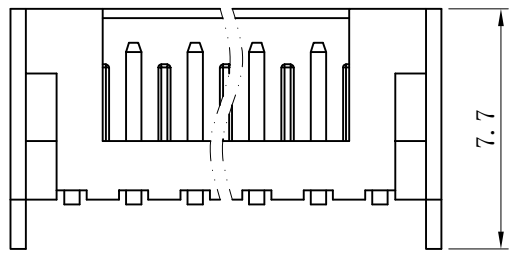
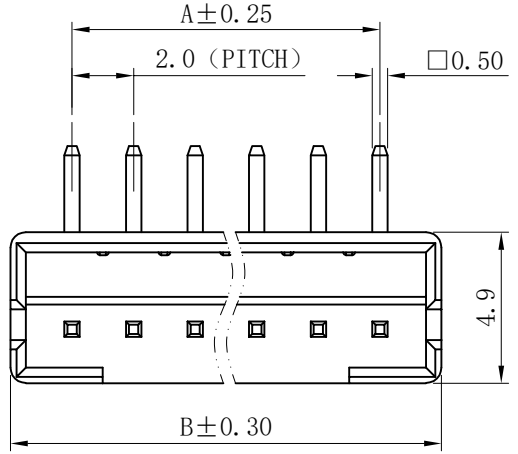

ROHS

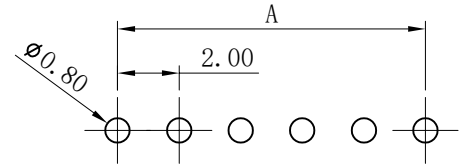

Recommended P.C.Board Hole Layout

Specifications / 技术规格:

Current rating: 2A
 额定电流: 2A
 Voltage rating: 100V AC,DC
 额定电压: 100V AC, DC
 Insulation Resistance: 1000MΩ Min.
 绝缘电阻: 最小1000MΩ
 Dielectric Withstanding: 800V AC 1Min
 耐电压: 800V AC 1分钟
 Contact Resistance: 20mΩ Max.
 接触电阻: 最大20mΩ
 Operating Temperature: -25°C to +85°C
 工作温度: -25° C 到85° C

Materials / 材料:

Contact Material: Brass(Tin plating)
 接触端子材料: 黄铜(镀锡)
 Insulation Material:
 PA 或 PBT UL94V-2

浙江快利电子有限公司
 Zhejiang Kuaili Electronic Co., Ltd

GENERAL TOLERANCE	
X.* ± 3'	X. --
.X* ± 2'	.X ±0.30
.XX* ± 1'	.XX ±0.20
.XXX* ± 0.5'	.XXX --

DESIGN: KEVIN	DATE: 15'.3.10
CHECKED:	DATE:
AUDITED:	DATE:
APPROVED:	DATE:

DWG. NO.	PART NO. KL-PH-NAWD-01-W
TITLE.	

TITLE:
 PH-NAWD 连接器

REV. A	UNIT. MM	SCALE. 1:1	
--------	----------	------------	--

1 2 3 4 5 6 7 8 9