

REV.	ECN NO	DESCRIPTION	REVISED	DATE
A		新订图面	HELLER	2019.03.20

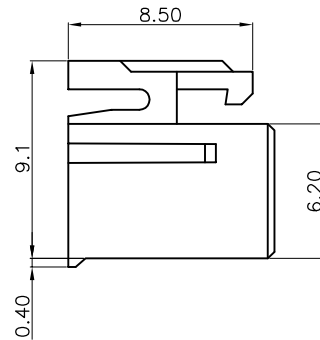
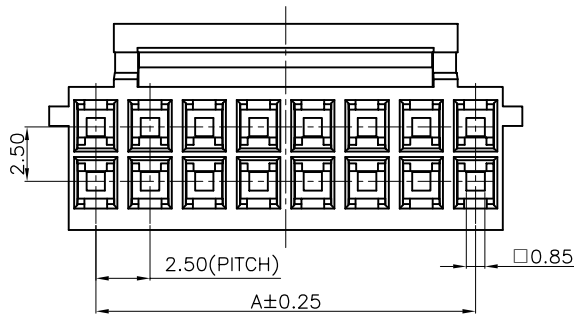
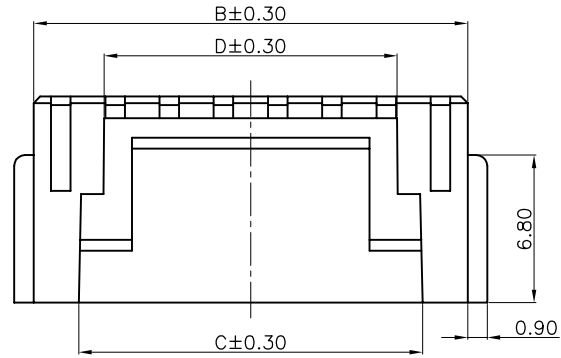

PIN数	尺寸 (mm)			
	A	B	C	D
2×8	17.5	20.0	15.85	13.50
2×9	20.0	22.5		
2×10	22.5	25.0		
2×11	25.0	27.5		
2×12	27.5	30.0		
2×13	30.0	32.5		
2×14	32.5	35.0		
2×15	35.0	37.5		
2×16	37.5	40.0		

SPECIFICATIONS:

1. Operation temperature : -25~+85° C;
2. Current rating: 3.0A;
3. Voltage rating: 250V DC/AC;
4. Insulation resistance: 1000MΩ min;
5. Dielectric voltage: 1000V AC /1minute;
6. Environmental requirement: according to ROHS standard.

MATERIAL:

Insulation Material: PA or PBT UL94V-2

PART NO.

KL-HXB2.5-2XNY Black

KL-HXB2.5-2XNY-WT White

 **浙江快利电子有限公司**
ZheJiang KuaiLi Electronic Co., LTD.

GENERAL TOLERANCE

X.: ± 3'	X.: ±0.35
.X: ± 2'	X.X: ±0.25
.XX: ± 1'	X.XX: ±0.15
.XXX: ± 0.5'	X.XXX: ±0.10

DESIGN: HELLER

DATE: 2019-03-20

DWG. NO.

TITLE.

CHECKED: 朱建慧

DATE: 2019-03-20

PART NO.

HXB2.5-2XNY

APPROVED: 朱建华

DATE: 2019-03-20

REV.	UNIT.	SCALE.	PROJ.
A	mm	-	