

REV.	ECN NO	DESCRIPTION	REVISED	DATE
A		新订图面	KEVIN	14.05.20

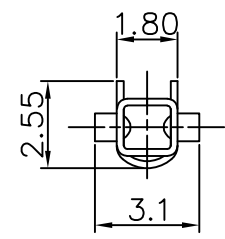

此处刻公司LOGO (KL)

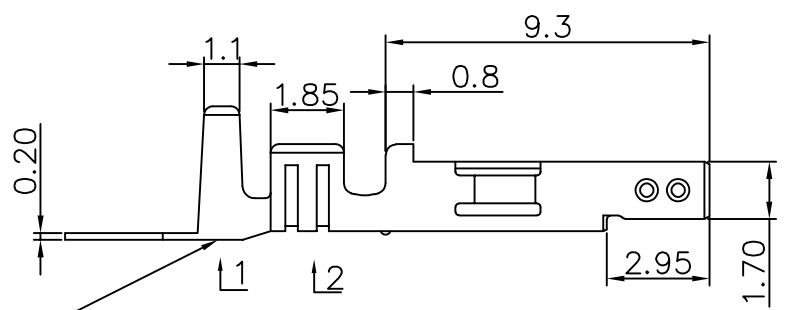
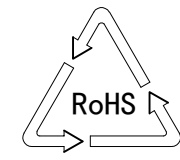
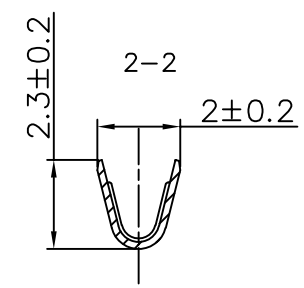
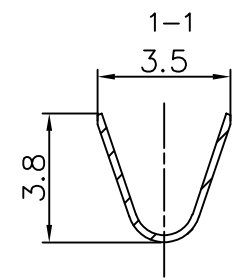
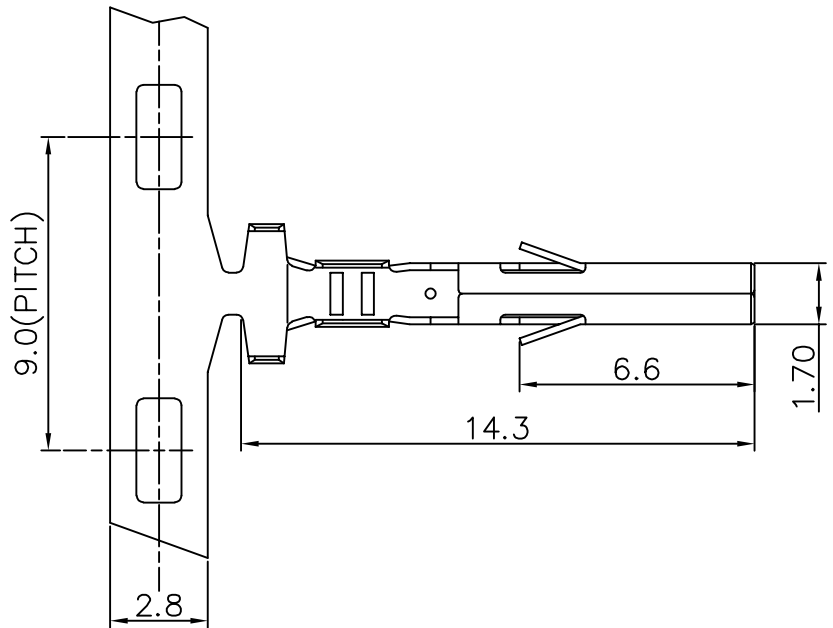

材料名称	材料厚度	表面处理	适用导线规格	备注
锡青铜	0.2mm	镀锡	AWG24#~20#	

浙江快利电子有限公司
Zhejiang Kuaili Electronic Co., Ltd

GENERAL TOLERANCE	
X* ± 3'	.XXX: ±0.10
.X* ± 2'	.XX : ±0.15
.XX* ± 1'	.X : ±0.25
.XXX* ± 0.5'	X. : ±0.35

DESIGN: KEVIN
CHECKED:
AUDITED:
APPROVED:

DATE: 2014-05-20
DATE:
DATE:
DATE:

DWG. NO.
PART NO.
KL-C36501G-TE

TITLE.
C36501G-TE

REV.	A	UNIT.	MM	SCALE.	1:1
------	---	-------	----	--------	-----

