

REV.	ECN NO	DESCRIPTION	REVISED	DATE
A		新订图面	LXM	2016.6.18

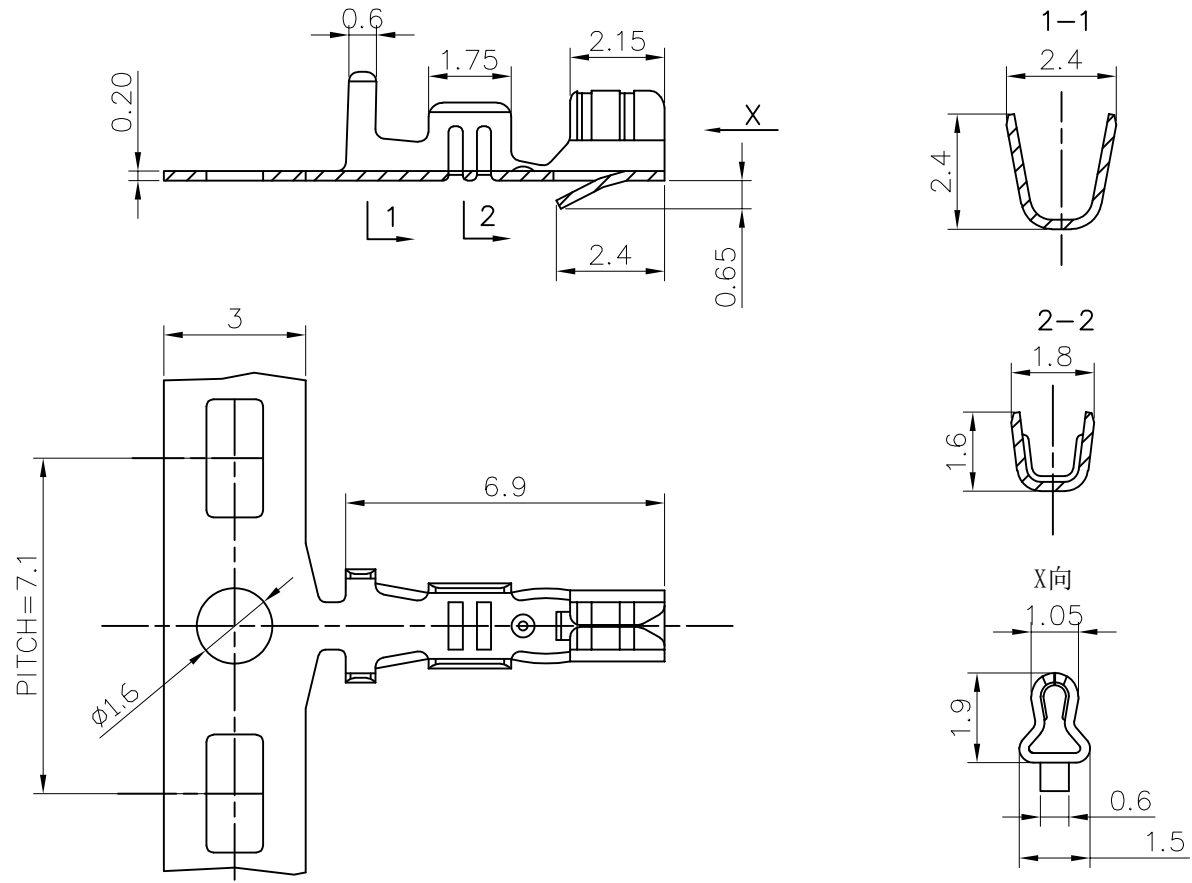

Specifications / 技术规格:

Current Rating: 3A
 额定电流: 3A
 Insulation Resistance: 1000 MΩ Min.
 绝缘电阻: 最小1000MΩ
 Dielectric Withstanding: 1000V AC
 耐电压: 1000V AC
 Contact Resistance: 20mΩ Max.
 接触电阻: 最大20mΩ
 Operating Temperature: -25° C to +85° C
 工作温度: -25° C 到 85° C

Materials / 材料:

Contact Material: Phosphor Bronze (Tin plating)
 接触端子材料: 磷铜(镀锡)
 Recommended wire gauge: AWG28#-24#
 推荐线规: AWG28#-24#

浙江快利电子有限公司
 ZheJiang KuaiLi Electronic Co., LTD.

GENERAL TOLERANCE	
X.: ± 3°	X.: ±0.35
.X: ± 2°	X.X: ±0.25
.XX: ± 1°	X.XX: ±0.15
.XXX: ± 0.5°	X.XXX: ±0.10

DESIGN:	李晓明	DATE:	2016-06-18
CHECKED:	曹德友	DATE:	2016-06-18
APPROVED:	朱建华	DATE:	2016-06-18

DWG. NO.	
PART NO.	KL-5264-TE-2824

TITLE.	5264-TE
--------	---------

REV.	UNIT.	SCALE.	PAGE.	PROJ.
A	mm	-	1/1	⊕