

1 2 3 4 5 6 7 8 9

F

E

D

C

B

A

F

E

D

C

B

A

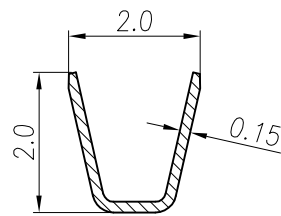
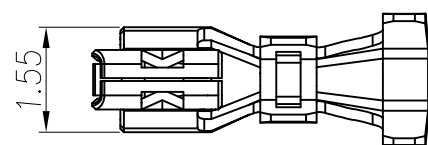

SECT. A-A

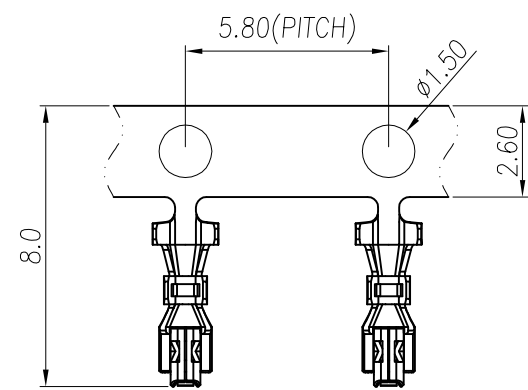

排样图
SCALE 0.5:1

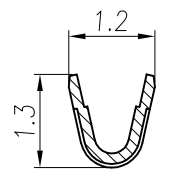
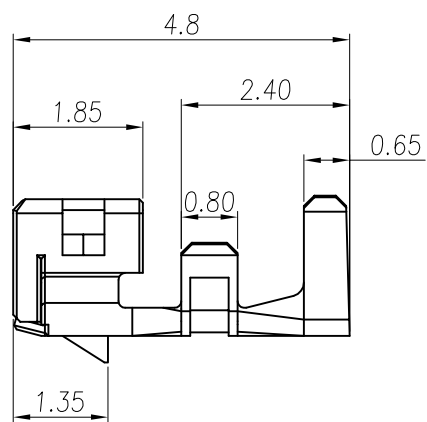
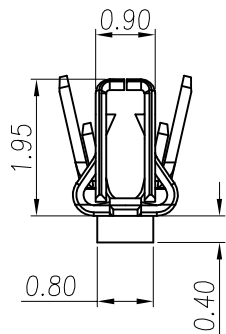

SECT. A-A

Specifications / 技术规格:

Current Rating: 2A
 额定电流: 2A
 Voltage rating: 125V AC,DC
 额定电压: 125V AC,DC
 Insulation Resistance: 1000 MΩ Min.
 绝缘电阻: 最小1000MΩ
 Dielectric Withstanding: 500V AC
 耐电压: 500V AC
 Contact Resistance: 20mΩ Max.
 接触电阻: 最大20mΩ
 Operating Temperature: -25°C to +85°C
 工作温度: -25°C 到 85°C

Materials / 材料:

Contact Material: Phosphor Bronze
 接触端子材料: 磷铜

Finish / 表面处理: Tin plated 镀锡

 浙江快利电子有限公司
 Zhejiang Kuaili Electronic Co., Ltd

GENERAL TOLERANCE

X.° ± 3'	.XXX: ±0.10
.X° ± 2'	.XX: ±0.15
.XX° ± 1'	.X: ±0.25
.XXX° ± 0.5'	X: ±0.35

DESIGN: HELLER
 AUDITED: 朱建慧
 APPROVED: 朱建华

DATE: 18'.11.19
 DATE: 18'.11.19
 DATE: 18'.11.19

DWG. NO.
 PART NO.
 KL-3535-TE

TITLE.
 2.0间距单排T型扣端子
 3535-TE

1 2 3 4 5 6 7 8 9