

1 2 3 4 5 6 7 8 9

ROHS

| REV. | ECN NO | DESCRIPTION | REVISED | DATE |
|------|--------|-------------|---------|------|
| A    |        | 新订图面        | KEVIN   |      |

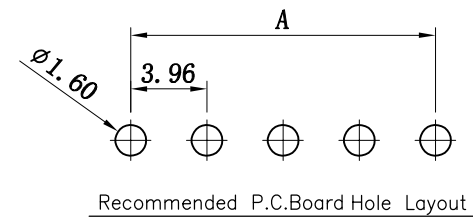
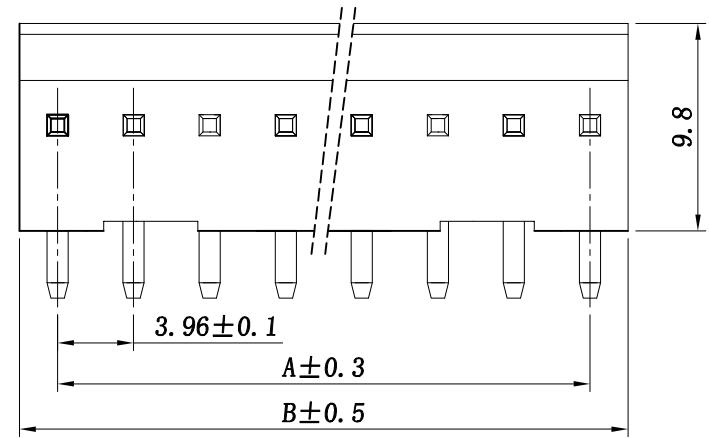

Specifications / 技术规格:

Current rating: 5A  
 额定电流: 5A  
 Voltage rating: 250V AC, DC  
 额定电压: 250V AC, DC  
 Insulation Resistance: 1000MΩ Min.  
 绝缘电阻: 最小1000MΩ  
 Dielectric Withstanding: 1500V AC 1Min  
 耐电压: 1500V AC 1分钟  
 Contact Resistance: 20mΩ Max.  
 接触电阻: 最大20mΩ  
 Operating Temperature: -25°C to +85°C  
 工作温度: -25°C 到85°C

Materials / 材料:

Contact Material: Brass(Sn plating)  
 接触端子材料: 黄铜(镀锡)  
 Insulation Material: PA66 UL94 V-0(2)

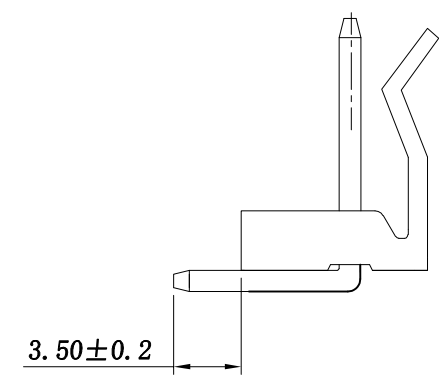
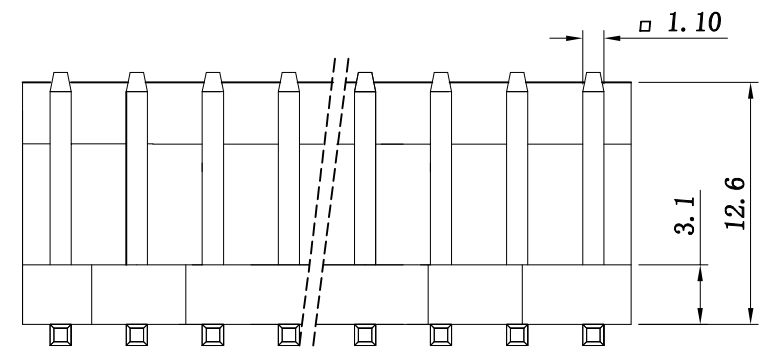

| 孔数 | 型号        | 尺寸 (mm) |       |
|----|-----------|---------|-------|
|    |           | A       | B     |
| 2  | 3.96-2AW  | 3.96    | 7.92  |
| 3  | 3.96-3AW  | 7.92    | 11.88 |
| 4  | 3.96-4AW  | 11.88   | 15.84 |
| 5  | 3.96-5AW  | 15.84   | 19.8  |
| 6  | 3.96-6AW  | 19.80   | 23.76 |
| 7  | 3.96-7AW  | 23.76   | 27.72 |
| 8  | 3.96-8AW  | 27.72   | 31.68 |
| 9  | 3.96-9AW  | 31.68   | 35.64 |
| 10 | 3.96-10AW | 35.64   | 39.6  |
| 11 | 3.96-11AW | 39.6    | 43.56 |
| 12 | 3.96-12AW | 43.56   | 47.52 |

浙江快利电子有限公司  
 Zhejiang Kuaili Electronic Co., Ltd

REV. A UNIT. MM SCALE. 1:1

| GENERAL TOLERANCE |            |
|-------------------|------------|
| X.* ± 3'          | .XXX ±0.10 |
| .X* ± 2'          | .XX ±0.15  |
| .XX* ± 1'         | .X ±0.25   |
| .XXX* ± 0.5'      | X. ±0.35   |

DESIGN: KEVIN DATE: 15'.3.10  
 CHECKED: DATE:  
 AUDITED: DATE:  
 APPROVED: DATE:

DWG. NO.  
 PART NO. KL-3.96-NAW

TITLE. 3.96-NAW连接器

1 2 3 4