

REV.	ECN NO	DESCRIPTION	REVISED	DATE
A		新订图面	KEVIN	

ROHS

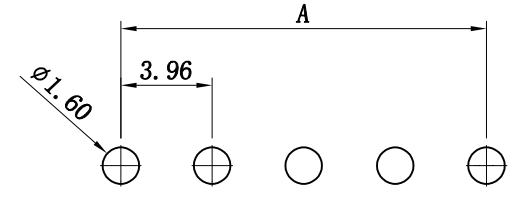

Recommended P.C.Board Hole Layout

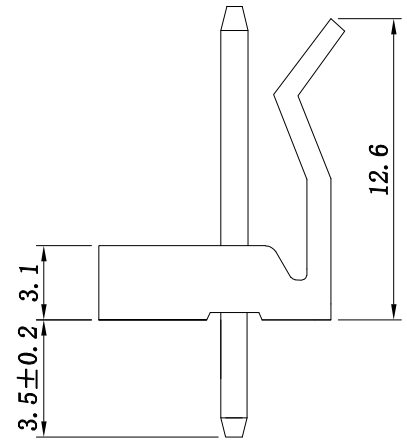
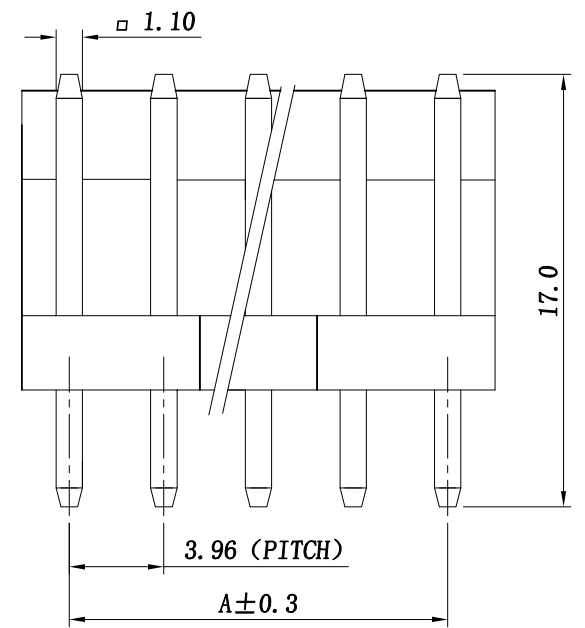
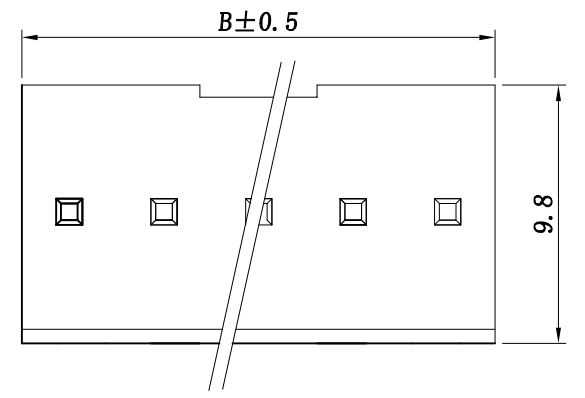

Specifications / 技术规格:

Current rating: 5A
 额定电流: 5A
 Voltage rating: 250V AC,DC
 额定电压: 250V AC,DC
 Insulation Resistance: 1000MΩ Min.
 绝缘电阻: 最小1000MΩ
 Dielectric Withstanding: 1500V AC 1Min
 耐电压: 1500V AC 1分钟
 Contact Resistance: 20mΩ Max.
 接触电阻: 最大20mΩ
 Operating Temperature: -25°C to +85°C
 工作温度: -25°C 到 85°C

Materials / 材料:
 Contact Material: Brass(Sn plating)
 接触端子材料: 黄铜(镀锡)
 Insulation Material: PA6 UL94V-2
 绝缘体塑胶材质: PA6 UL94V-2

孔数	型号	尺寸 (mm)	
		A	B
2	3.96-2A	3.96	7.92
3	3.96-3A	7.92	11.88
4	3.96-4A	11.88	15.84
5	3.96-5A	15.84	19.8
6	3.96-6A	19.80	23.76
7	3.96-7A	23.76	27.72
8	3.96-8A	27.72	31.68
9	3.96-9A	31.68	35.64
10	3.96-10A	35.64	39.6
11	3.96-11A	39.6	43.56
12	3.96-12A	43.56	47.52

 **浙江快利电子有限公司**
 Zhejiang Kuaili Electronic Co., Ltd

REV. A UNIT. MM SCALE. 1:1

GENERAL TOLERANCE	
X.* ± 3'	X. ±0.35
.X* ± 2'	.X ±0.25
.XX* ± 1'	.XX ±0.15
.XXX* ± 0.5'	.XXX ±0.10

DESIGN: KEVIN
 CHECKED:
 AUDITED:
 APPROVED:

DATE: 2015-09-08
 DATE:
 DATE:
 DATE:

DWG. NO.
 PART NO.
 KL-3.96-NA

TITLE.
 3.96-NA连接器