

REV.	ECN NO	DESCRIPTION	REVISED	DATE
A		新订图面	HELLER	2022.07.28

RECOMMENDED P.C.BOARD LAYOUT(TOP VIEW)
GENERAL TOLERANCE : ±0.05

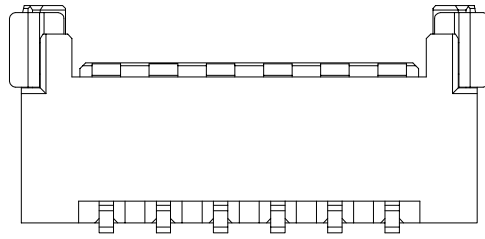

CKT.	A	B
2	2.00	7.95
3	4.00	9.95
4	6.00	11.95
5	8.00	13.95
6	10.00	15.95

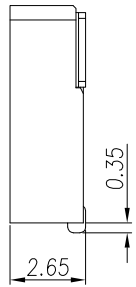
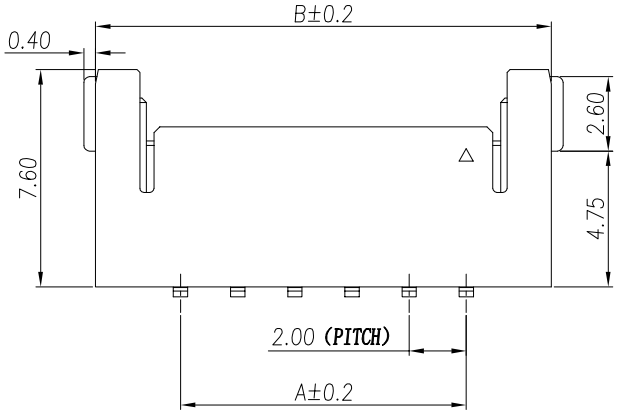
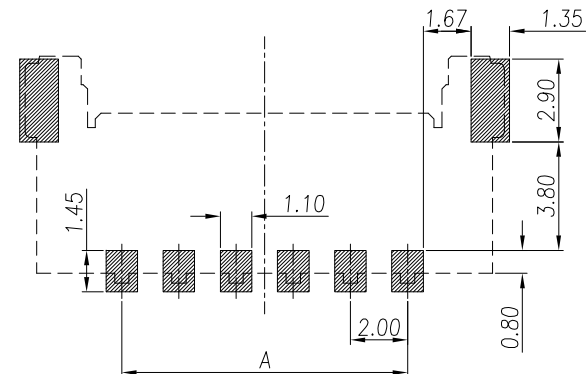
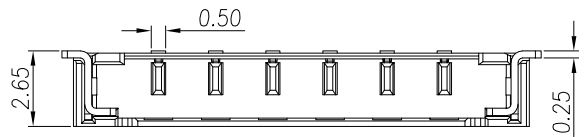
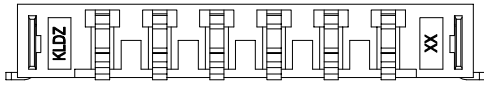

规格:

- 材料:
 - 胶芯材料: 热塑性高温塑料 UL94V-0 黑色.
 - 焊片材料: 磷铜, 镀镍&锡.
 - 插针材料: 磷铜, 镀镍&锡.
- 额定电压: 250V AC.
- 额定电流: 3.0A.
- 接触电阻: 最大40mΩ (试验后量测).
- 绝缘电阻: 1000MΩ.
- 耐电压: 800V/1分钟.
- 操作温度: -25℃~85℃.

 浙江快利电子有限公司
ZheJiang KuaiLi Electronic Co., LTD.

GENERAL TOLERANCE	
X.° ± 3'	X. ±0.35
.X° ± 2'	.X ±0.25
.XX° ± 1'	.XX ±0.15
.XXX° ± 0.5'	.XXX ±0.10

DESIGN: HELLER
CHECKED: 朱建慧
APPROVED: 朱建华

DATE: 2022.07.28
DATE: 2022.07.28
DATE: 2022.07.28

DWG. NO.
PART NO.
KL-2053-NAWT

TITLE.
2053-NAWT

REV.	A	UNIT.	MM	SCALE.	-
					