

REV.	ECN NO	DESCRIPTION	REVISED	DATE
A		新订图面	KEVIN	2016.4.18

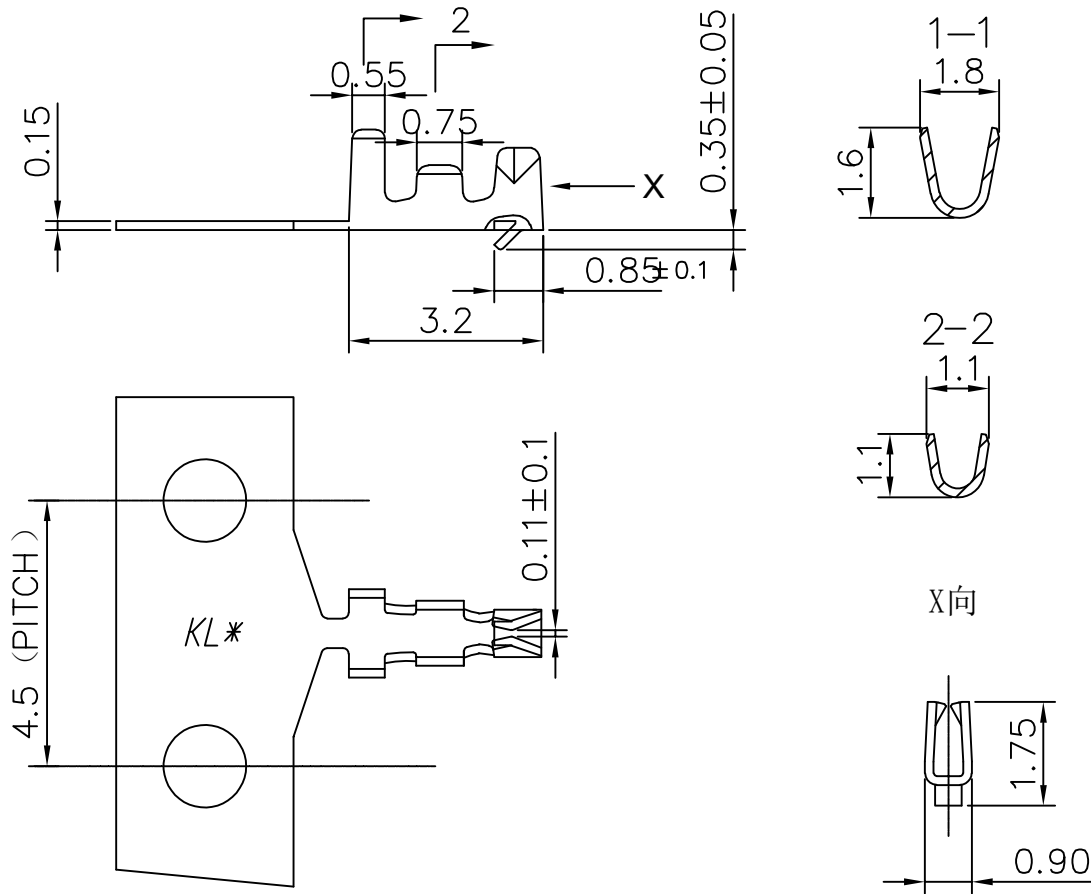

Specifications / 技术规格:

Current Rating: 1A
 额定电流: 1A
 Insulation Resistance: 500MΩ Min.
 绝缘电阻: 最小500MΩ
 Dielectric Withstanding: 500V AC
 耐电压: 500V AC
 Contact Resistance: 20mΩ Max.
 接触电阻: 最大20mΩ
 Operating Temperature: -25°C to +85°C
 工作温度: -25°C 到 85°C

Materials / 材料:

Contact Material: Phosphor Bronze (Tin plating)
 接触端子材料: 磷铜 (镀锡)
 Recommended cable gauge: AWG26#-30#
 推荐线规: AWG26#-30#

浙江快利电子有限公司
 ZheJiang KuaiLi Electronic Co., LTD.

GENERAL TOLERANCE

X: ± 3°	X.: ±0.35
.X: ± 2°	X.X: ±0.25
.XX: ± 1°	X.XX: ±0.15
.XXX: ± 0.5°	X.XXX: ±0.10

DESIGN:	KEVIN	DATE:	2016-04-18
CHECKED:	李晓明	DATE:	2016-04-18
APPROVED:	朱建华	DATE:	2016-04-18

DWG. NO.	KL-1.25-TE-3026
PART NO.	

TITLE.	1.25-TE
--------	---------

REV.	UNIT.	SCALE.	PAGE.	PROJ.
A	mm	-	1/1	⊕